

Instruction Manual

impression[®]
X4BAR



10

from software version: v0.60



— since 1994 —

support@glp.de
www.glp.de

Contents

1	Description of Device	3
2	Safety Instructions	4
3	Mounting	6
3.1.1	Operating on the Floor (Upright).....	7
3.1.2	Mounting in hanging or sideways position	7
3.2	Securing the Fixture	7
3.3	Alignment of the Fixtures	8
3.4	Connections.....	8
3.4.1	Power Supply	8
3.4.2	DMX.....	9
4	The Menu Field	10
5	DMX Chanel Selection (DMX Protocol)	12
5.1	Normal Mode (norm) 33 DMX channels:	13
5.2	Compressed Mode (comp) 19 DMX Channels:	15
5.3	High Resolution Mode (Hires) 34 DMX Channels:.....	17
5.4	Dual Pixel Mode (dpix) 28 DMX Channels:	19
5.5	Dual Pixel High Resolution Mode (DPixH) 29 DMX Channels:	20
5.6	Single Pixel Mode (spix) 48 DMX Channels:	21
5.7	Single Pixel High Resolution (SPixH) Mode 49 DMX Channels:.....	23
6	Accessories.....	26
6.1	Optional diffuser filter:	26
7	Maintaining and Cleaning	27
7.1	Safety regulations	27
7.2	Maintenance and Interval (rule-of-thumb).....	27
8	Technical Specifications:	28
9	Dimensions	29

1 Description of Device

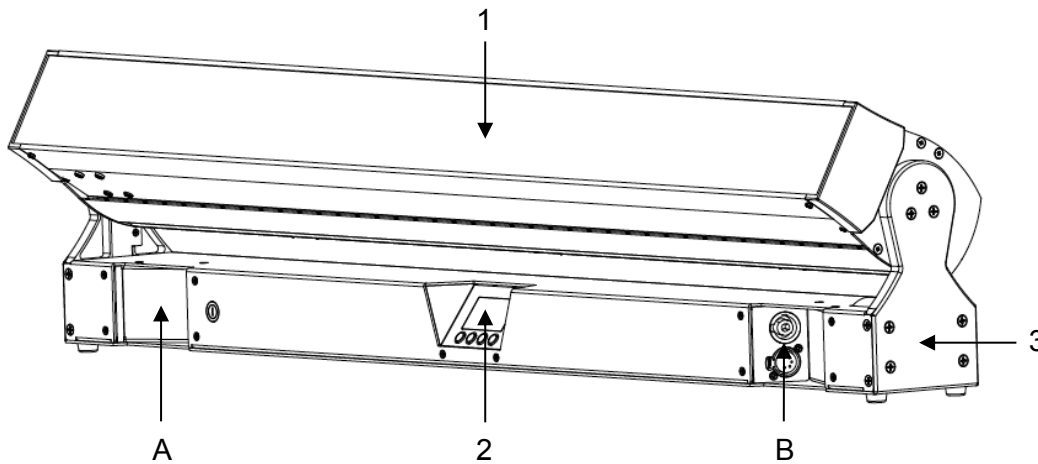

- 1. Moving Bar (actively and passively cooled)
- 2. LCD-Display / Menu (data entry)
- 3. Base with rubber feet and Camlock mounting system

A) Base side left

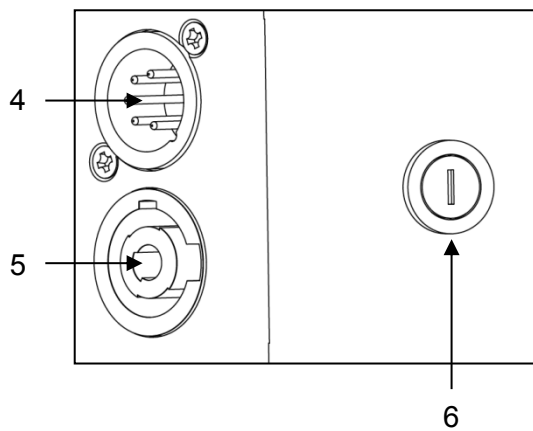

- 4. DMX Input (5 pin)
- 5. Mains Input (blue powerCON)
- 6. Micro-fuse 5x20mm, T5A

B) Base side right

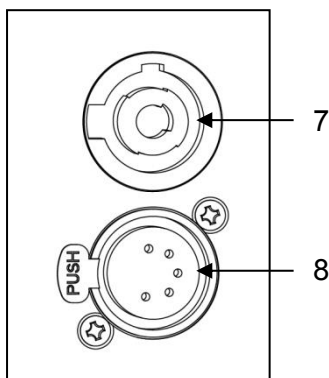

- 7. Mains Output (white powerCON)
- 8. DMX Output (5 pin)

2 Safety Instructions



The **IMPRESSION X4 Bar 10** is a High-Tech Product. To guarantee a smooth operation, it is necessary to respect the following rules. The manufacturer of this device will not take responsibility for damages through any disregard of the information provided in this manual. Warranty claims also will be voided in the case that the fixture housing is opened.



Never look directly into the beam of light or into one of the LEDs. **Attention:** LED Class 2M can cause injuries of your eyes even without optical instruments in front of them or within a distance of less than 0.5m and short exposure time.
Hence: Avoid direct radiation into your eyes!



WARNING:

Never let optical parts come in contact with alcohol, solvents or similar cleaners.

1. Before powering on the fixture, make sure that the fixtures fans and air inlets are clean and not blocked.
2. Ensure that the fixture head can rotate unhindered throughout its complete range of pan and tilt movement. A safety distance of at least 0.5 m must be maintained between the fixture and any easily inflammable material (e.g. decoration material).
3. **Attention!** Don't touch the fixture during the operation. This can cause injuries and/or damages.
4. **The fixture doesn't contain any user serviceable parts. Opening the fixture will void all warranties.**
5. It is necessary to wait at least 15 minutes after disconnecting the mains power before handling the fixture. Pay attention to possible hot parts of the fixture.
6. To ensure safe operation, follow also the Installation guide described in the chapter below. Operating the **IMPRESSION X4 Bar 10** without suitable safety aids like Safety cables or clamps/hooks can increase the risk of an accident and must be avoided.
7. Repair, maintenance, and installation work shall be done by qualified or GLP certified staff only. You need to pay attention to the common rules of technology that are not explicitly mentioned in this manual.
8. Use only original GLP spare parts. Any structural modification of the system will terminate all warranty claims.
9. Please keep this instruction manual for future reference.



Important Safety Information

The **IMPRESSION X4 Bar 10** fixture from GLP is fitted with a number of plano-convex lenses in a highly efficient collimator cluster. This type of lens can act as a strong magnifying glass.

If the rays from a strong light source (such as the sun or another lighting fixture) are directed towards the front of any of these fixtures, then internal damage may occur. In a worst case scenario with a high power light source this can happen very quickly, damaging the fixture internally, potentially melting components or causing an internal fire within seconds.

In order to avoid these possible problems please adhere to the following requirements:

- Do not expose the front of a fixture to direct sunlight or any other strong light sources.
- For outdoor applications during daylight make sure that the front face of any fixture is either shielded or points away from the sun, even when fixtures are not in use.
- Do not modify the front glass or lenses of any fixture.

These requirements have to be followed regardless of whether a fixture is powered on or off as the magnifying effect is an optical effect and therefore independent from the (electrical) state of the fixture.

Especially when working with high powered **beam-lights**; extreme caution and observance of these safety instructions is mandatory.

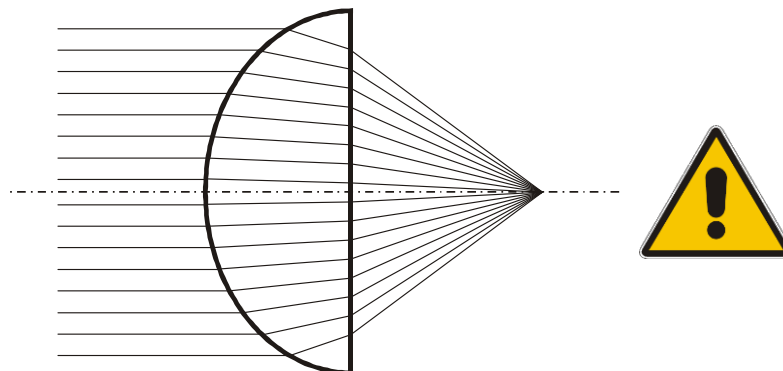

Should you have any questions about the operation of your fixture then please contact your local GLP office, or their authorized distributor, a list of which can be found at www.glp.de.

3 Mounting

The **IMPRESSION X4 Bar 10** is fully operational whether it hangs or is mounted to the wall. It can also be operated while standing on the floor. Keep a safety distance of min. 0.5 m towards any easily inflammable materials (decoration etc.).

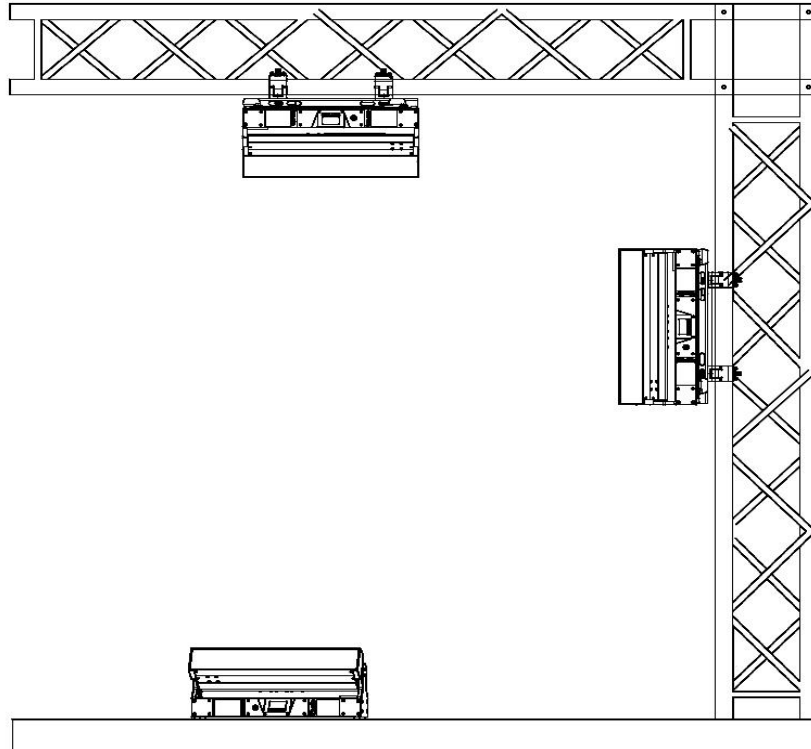

Pay attention to the regulations of: BGV C1 (former VBG 70) and DIN VDE 0711-217.

The installation shall be done by qualified staff only.

For the various mounting positions of the **IMPRESSION X4 Bar 10** (standing on the floor, sideways or hanging) different accessories kits are available. Through this a safe and firm installation is assured. You'll find dedicated connectors on the bottom side of the fixture which should be used.

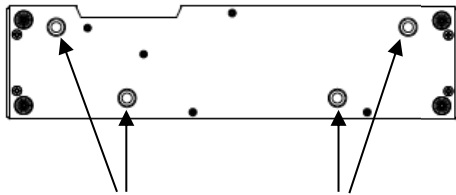

4 x Camlock for bracket

3.1.1 Operating on the Floor (Upright)

The **IMPRESSION X4 Bar 10** is fitted with 4x solid rubber feet which allows a stable standing of the fixture. An additional securing is usually not required. Please pay attention to an even and gripping surface.

3.1.2 Mounting in hanging or sideways position

To operate the **IMPRESSION X4 Bar 10** in a hanging position please use the dedicated bracket supplied with your fixture. It is fixed to the base of the fixture with fasteners called Camlock quick-release connectors. Insert the four fasteners and turn each 90° to lock them. Do the opposite to release them again.

3.2 Securing the Fixture

Regardless of the mounting method of the **IMPRESSION X4 Bar 10** you'll have to use a stipulated safety wire.

Attach the safety wire through the attachment point shown below and connect it to the primary support structure.

The safety attachment point can be deployed by simply swinging it out from the base.

Pay attention to a safe and proper fastening. The safety cable must comply with BGI 810-3 (EN 60598-2-17 Section 17.6.6) and be capable of bearing a static suspended load that is ten times the weight of the fixture and all installed accessories.

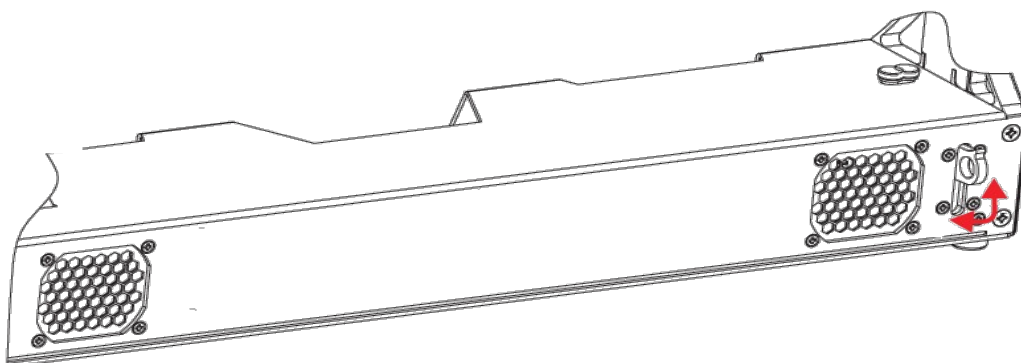

3.3 Alignment of the Fixtures

For precise and easy alignment of multiple fixtures the **IMPRESSION X4 Bar 10** is equipped with alignment pins on the side.

To deploy them, simply slide them to the side and insert the pins in the related holes of the next fixture.

Push the knob down to slide the pins in again after every usage to avoid any damage or injuries that could be caused by them.

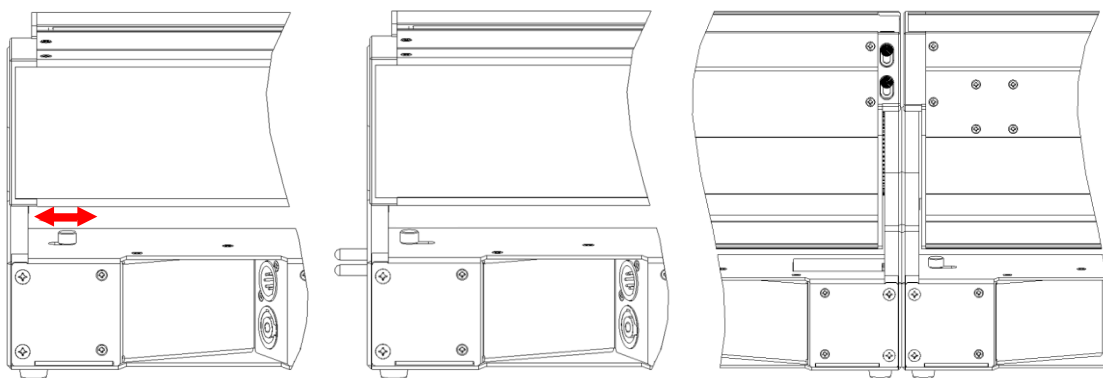

3.4 Connections

3.4.1 Power Supply

~100-240 Volt AC, 50-60 Hz, powerCON AC connector

Connected load 200 VA (W) <=> T5A (micro-fuse 5x20mm)

Please see printing on the case for the right electronic supply!

Disconnect from the mains supply for changing the fuse and use only the above described micro-fuse type.

NEUTRIK® powerCON

The **IMPRESSION X4 Bar 10** is fitted with NEUTRIK® powerCON locking 3 conductor AC connectors.

The grey connector must be used to draw AC mains power from the fixtures` throughput sockets and the blue connectors must be used to supply power at the fixtures` power input socket.

The total number of fixtures in one interconnected chain depends on your local AC mains voltage but you must never connect more than a total load of 20A to stay within the limits of the connector. The total load includes all connected fixtures including the first one in the chain.

Note: The maximum allowed total - load is 20A including the first fixture in one interconnected daisy chain.

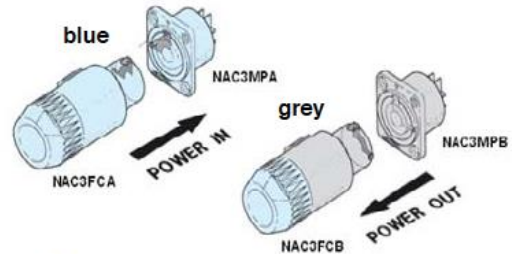

Picture: Courtesy of NEUTRIK® AG

3.4.2 DMX

USITT DMX-512 Standard input/output in 5-pin connectors.

Pin 1 = [Ground] / Pin 2 = [-] / Pin 3 = [+] / Pin 4&5 N.C.

The DMX- Addressing starts at the DMX- Address [001].

4 The Menu Field

You'll find the control board on the side part of the arm. It allows you to make all necessary adjustments of the **IMPRESSION X4 Bar**.

With the Mode-key you get into the main menu. Afterwards you can Navigate through the menu with the Up/Down-keys. Push the Enter-key to get in the next menu level or to confirm your settings. Make them and set functions ON/OFF with the Up/Down-keys. Confirm and save it with the Enter-key (the display shows OK). Push the Mode-key to cancel the entry and go back to the main menu.

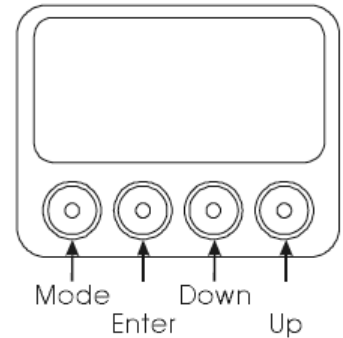

To lock or unlock the keys of the menu field press **Mode + Enter + Up** simultaneously.

← MODE - ENTER →

Level 1	Level 2	Level 3	Function
DMX Start Address 001			Set the DMX start address
Special	Set dimming mode	ESOFT	Set the dimming mode to extra-soft
		LIN	Set the dimming mode to linear
		SOFT	Set the dimming mode to soft
	DMX hold	On / Off	Enable / disable DMX hold when signal not present
	Silent mode	On / Off	Enable / disable Silent mode
	X4 compatibility	On / Off	Enable / disable X4 compatibility mode
	Test mode	On / Off	Enable / disable test program
	Set PWM frequency	1200	Set PWM frequency to 1200Hz
		600	Set PWM frequency to 600Hz
	Tilt reset	On / Off	Enable / disable Tilt movement for reset *
	Tilt current	On / Off	Enable / disable Tilt motor movement *
	Tilt slow	On / Off	Enable / disable slow Tilt speed *
	Default	OK	Reset all setting to default
	Temperature head		Read out the current temperature of the head in °C
	Temperature base		Read out the current temperature of the base in °C
	Boot count		Reset counter
	Fixture hours		Lifetime counter
	Adjust	Key Code	Internal adjustments for trained personnel only
Set DMX Mode	NORM		Set DMX mode to Normal
	SPIX		Set DMX mode to Single Pixel
	DPIXH		Set DMX mode to Dual Pixel High Resolution
	SPIXH		Set DMX mode to Single Pixel High Resolution

↑ DOWN - UP ↓

	DPIX
	HIRES
	COMP
Position feedback	On / Off
Reverse tilt	On / Off
Reverse pixel	On / Off
Reverse zoom	On / Off
Display flip	On / Off
Reset	OK

Set DMX mode to Dual Pixel
Set DMX mode to High Resolution
Set DMX mode to Compressed
Enable / disable position feedback function
Enable / disable inverted Tilt movement
Enable / disable inverted pixel count
Enable / disable inverted zoom movement
Enable / disable Display orientation
RESET and new calibration for all functions

* Requires Tilt Firmware V.20 or later. For further information please contact your local GLP dealer or GLP support center.

5 DMX Chanel Selection (DMX Protocol)

You can choose between 7 DMX modes each designed for different applications and preferences:

- **Normal Mode (33 Channels):**
Most common mode with all basic functions
- **Compressed Mode (19 Channels):**
Limited channel mode.
Channels are sorted to match the impression X4 normal mode.
- **High Resolution Mode (34 Channels):**
Same as the Normal Mode but with 16bit dimming
- **Single Pixel Mode (48 Channels):**
Individual control of the RGBW values for each pixel (i.e. for pixel mapping)
- **Single Pixel High Resolution Mode (49 Channels):**
Same as the Single Pixel Mode but with 16bit dimming
- **Dual Pixel Mode (28 Channels):**
Same as the the Single Pixel Mode but with 2 pixel combined as one to reduce the channel count.
- **Dual Pixel High Resolution Mode (29 Channels):**
Same as the Dual Pixel Mode but with 16bit dimming

5.1 Normal Mode (norm) 33 DMX channels:

Channel	Function	Time and Value	DMX
1 Tilt - High	Tilt coarse	0° - 210°	0..255
2 Tilt - Low	Tilt fine		0..255
3 Zoom	Wide (flood) - narrow (spot)	50° - 7°	0..255
4 CTO	No CTO		0..7
	Continuous color temperature correction	Applicable for ALL colors	8..255
5 Set 1 Color (fixed)	Colors adjustable via RGB		0..7
	Color 01 - Red ¹⁾		8..15
	Color 02 - Amber ¹⁾		16..23
	Color 03 - Warm Yellow ¹⁾		24..31
	Color 04 - Yellow ¹⁾		32..39
	Color 05 - Green ¹⁾		40..47
	Color 06 - Turquoise ¹⁾		48..55
	Color 07 - Cyan ¹⁾		56..63
	Color 08 - Blue ¹⁾		64..71
	Color 09 - Lavender ¹⁾		72..79
	Color 10 - Malve ¹⁾		80..87
	Color 11 - Magenta ¹⁾		88..95
	Color 12 - Pink ¹⁾		96..103
	White - CTO	3200K	104..111
	White	5600K	112..119
	White - CTB	7200K	120..127
Rainbow Effect Stop ²⁾		128	
Rainbow Effect ³⁾	slow - fast	129..223	
Random colors	slow - fast	224..255	
6 Set 1 Red	Color mixing system - Red	0 - 100%	0..255
7 Set 1 Green	Color mixing system - Green	0 - 100%	0..255
8 Set 1 Blue	Color mixing system - Blue	0 - 100%	0..255
9 Set 1 White	Color mixing system - White	0 - 100%	0..255
10 Set 1 Intensity	Intensity	0 - 100%	0..255
11 Shutter	Shutter closed		0..15
	Shutter pulse random	slow – fast	16..47
	Fade on, snap off (random patterns)	slow – fast	48..79
	Snap on, fade off (random patterns)	slow – fast	80..111
	Fade on, fade off (random patterns)	slow – fast	112..143
	Strobe random	5s - 0.1s	144..199

	Strobe effect slow - fast Shutter open	1 Hz - 10 Hz	200..239 240..255
12 Intensity	Intensity	0 - 100%	0..255
13 Special ⁵⁾	See special features below ⁵⁾	-	-
14 Set 2 Color ⁴⁾	Values see Channel 5	-	-
15 Set 2 Red ⁴⁾	Color mixing system - Red	0 - 100%	0..255
16 Set 2 Green ⁴⁾	Color mixing system - Green	0 - 100%	0..255
17 Set 2 Blue ⁴⁾	Color mixing system - Blue	0 - 100%	0..255
18 Set 2 White ⁴⁾	Color mixing system - White	0 - 100%	0..255
19 Set 2 Intensity ⁴⁾	Intensity	0 - 100%	0..255
20 Set 3 Color ⁴⁾	Values see Channel 5	-	-
21 Set 3 Red ⁴⁾	Color mixing system - Red	0 - 100%	0..255
22 Set 3 Green ⁴⁾	Color mixing system - Green	0 - 100%	0..255
23 Set 3 Blue ⁴⁾	Color mixing system - Blue	0 - 100%	0..255
24 Set 3 White ⁴⁾	Color mixing system - White	0 - 100%	0..255
25 Set 3 Intensity ⁴⁾	Intensity	0 - 100%	0..255
26 Crossfade	0..2 seconds transition time		0..255
27 Star Effect	Random internal shutter effect	slow – fast	0..255
28 Set 1 Pattern Select			0..255
29 Set 1 Pattern Movement			0..255
30 Set 2 Pattern Select			0..255
31 Set 2 Pattern Movement			0..255
32 Pixel Select 1 - 8			0..255
33 Pixel Select 9 - 10			0..255

5.2 Compressed Mode (comp) 19 DMX Channels:

Channel	Function	Time and Value	DMX
1 None	reserved		-
2 None	reserved		-
3 Tilt - High	Tilt coarse	0° - 210°	0..255
4 Tilt - Low	Tilt fine		0..255
5 Set 1 Color (fixed)	Colors adjustable via RGB		0..7
	Color 01 - Red ¹⁾		8..15
	Color 02 - Amber ¹⁾		16..23
	Color 03 - Warm Yellow ¹⁾		24..31
	Color 04 - Yellow ¹⁾		32..39
	Color 05 - Green ¹⁾		40..47
	Color 06 - Turquoise ¹⁾		48..55
	Color 07 - Cyan ¹⁾		56..63
	Color 08 - Blue ¹⁾		64..71
	Color 09 - Lavender ¹⁾		72..79
	Color 10 - Malve ¹⁾		80..87
	Color 11 - Magenta ¹⁾		88..95
	Color 12 - Pink ¹⁾		96..103
	White - CTO	3200K	104..111
	White	5600K	112..119
White - CTB	7200K	120..127	
Rainbow Effect Stop ²⁾		128	
Rainbow Effect ³⁾	slow - fast	129..223	
Random colors	slow - fast	224..255	
6 Set 1 Red	Color mixing system - Red	0 - 100%	0..255
7 Set 1 Green	Color mixing system - Green	0 - 100%	0..255
8 Set 1 Blue	Color mixing system - Blue	0 - 100%	0..255
9 Set 1 White	Color mixing system - White	0 - 100%	0..255
10 Shutter	Shutter closed		0..15
	Shutter pulse random	slow – fast	16..47
	Fade on, snap off (random patterns)	slow – fast	48..79
	Snap on, fade off (random patterns)	slow – fast	80..111
	Fade on, fade off (random patterns)	slow – fast	112..143
	Strobe random	5s - 0.1s	144..199
	Strobe effect slow - fast	1 Hz - 10 Hz	200..239
	Shutter open		240..255
11 Intensity	Intensity	0 - 100%	0..255

12 CTO	No CTO Continuous color temperature correction	Applicable for ALL colors	0..7 8..255
13 Special ⁵⁾	See special features below ⁵⁾	-	-
14 Crossfade	0..2 seconds transition time		0..255
15 Set 1 Pattern Movement			0..255
16 Zoom	Wide (flood) - narrow (spot)	50° - 7°	0..255
17 Set 1 Pattern Select			0..255
18 Pixel Select 1 - 8			0..255
19 Pixel Select 9 - 10			0..255

5.3 High Resolution Mode (Hires) 34 DMX Channels:

Channel	Function	Time and Value	DMX
1 Tilt - High	Tilt coarse	0° - 210°	0..255
2 Tilt - Low	Tilt fine		0..255
3 Zoom	Wide (flood) - narrow (spot)	50° - 7°	0..255
4 CTO	No CTO		0..7
	Continuous color temperature correction	Applicable for ALL colors	8..255
5 Set 1 Color (fixed)	Colors adjustable via RGB		0..7
	Color 01 - Red ¹⁾		8..15
	Color 02 - Amber ¹⁾		16..23
	Color 03 - Warm Yellow ¹⁾		24..31
	Color 04 - Yellow ¹⁾		32..39
	Color 05 - Green ¹⁾		40..47
	Color 06 - Turquoise ¹⁾		48..55
	Color 07 - Cyan ¹⁾		56..63
	Color 08 - Blue ¹⁾		64..71
	Color 09 - Lavender ¹⁾		72..79
	Color 10 - Malve ¹⁾		80..87
	Color 11 - Magenta ¹⁾		88..95
	Color 12 - Pink ¹⁾		96..103
	White - CTO	3200K	104..111
	White	5600K	112..119
	White - CTB	7200K	120..127
Rainbow Effect Stop ²⁾		128	
Rainbow Effect ³⁾	slow - fast	129..223	
Random colors	slow - fast	224..255	
6 Set 1 Red	Color mixing system - Red	0 - 100%	0..255
7 Set 1 Green	Color mixing system - Green	0 - 100%	0..255
8 Set 1 Blue	Color mixing system - Blue	0 - 100%	0..255
9 Set 1 White	Color mixing system - White	0 - 100%	0..255
10 Set 1 Intensity	Intensity	0 - 100%	0..255
11 Shutter	Shutter closed		0..15
	Shutter pulse random	slow – fast	16..47
	Fade on, snap off (random patterns)	slow – fast	48..79
	Snap on, fade off (random patterns)	slow – fast	80..111
	Fade on, fade off (random patterns)	slow – fast	112..143
	Strobe random	5s - 0.1s	144..199

	Strobe effect slow - fast	1 Hz - 10 Hz	200..239
	Shutter open		240..255
12 Intensity - High	Intensity - coarse	0 - 100%	0..255
13 Intensity - Low	Intensity - fine	-	0..255
14 Special ⁵⁾	See special features below ⁵⁾	-	-
15 Set 2 Color ⁴⁾	Values see Channel 5	-	-
16 Set 2 Red ⁴⁾	Color mixing system - Red	0 - 100%	0..255
17 Set 2 Green ⁴⁾	Color mixing system - Green	0 - 100%	0..255
18 Set 2 Blue ⁴⁾	Color mixing system - Blue	0 - 100%	0..255
19 Set 2 White ⁴⁾	Color mixing system - White	0 - 100%	0..255
20 Set 2 Intensity ⁴⁾	Intensity	0 - 100%	0..255
21 Set 3 Color ⁴⁾	Values see Channel 5	-	-
22 Set 3 Red ⁴⁾	Color mixing system - Red	0 - 100%	0..255
23 Set 3 Green ⁴⁾	Color mixing system - Green	0 - 100%	0..255
24 Set 3 Blue ⁴⁾	Color mixing system - Blue	0 - 100%	0..255
25 Set 3 White ⁴⁾	Color mixing system - White	0 - 100%	0..255
26 Set 3 Intensity ⁴⁾	Intensity	0 - 100%	0..255
27 Crossfade	0..2 seconds transition time		0..255
28 Star Effect	Random internal shutter effect	slow – fast	0..255
29 Set 1 Pattern Select			0..255
30 Set 1 Pattern Movement			0..255
31 Set 2 Pattern Select			0..255
32 Set 2 Pattern Movement			0..255
33 Pixel Select 1 - 8			0..255
34 Pixel Select 9 - 10			0..255

5.4 Dual Pixel Mode (dpix) 28 DMX Channels:

Channel	Function	Time and Value	DMX
1 Tilt - High	Tilt coarse	0° - 210°	0..255
2 Tilt - Low	Tilt fine		0..255
3 Shutter	Shutter closed		0..15
	Shutter pulse random	slow – fast	16..47
	Fade on, snap off (random patterns)	slow – fast	48..79
	Snap on, fade off (random patterns)	slow – fast	80..111
	Fade on, fade off (random patterns)	slow – fast	112..143
	Strobe random	5s - 0.1s	144..199
	Strobe effect slow - fast	1 Hz - 10 Hz	200..239
	Shutter open		240..255
4 Intensity	Intensity	0 - 100%	0..255
5 CTO	No CTO	Applicable	0..7
	Continuous color temperature correction	for ALL colors	8..255
6 Special ⁵⁾	See special features below ⁵⁾	-	-
7 Crossfade	0..2 seconds transition time		0..255
8 Zoom	Wide (flood) - narrow (spot)	50° - 7°	0..255
9 Set 1&2 Red	Color mixing system - Red	0 - 100%	0..255
10 Set 1&2 Green	Color mixing system - Green	0 - 100%	0..255
11 Set 1&2 Blue	Color mixing system - Blue	0 - 100%	0..255
12 Set 1&2 White	Color mixing system - White	0 - 100%	0..255
13 Set 3&4 Red	Color mixing system - Red	0 - 100%	0..255
14 Set 3&4 Green	Color mixing system - Green	0 - 100%	0..255
15 Set 3&4 Blue	Color mixing system - Blue	0 - 100%	0..255
16 Set 3&4 White	Color mixing system - White	0 - 100%	0..255
17 Set 5&6 Red	Color mixing system - Red	0 - 100%	0..255
18 Set 5&6 Green	Color mixing system - Green	0 - 100%	0..255
19 Set 5&6 Blue	Color mixing system - Blue	0 - 100%	0..255
20 Set 5&6 White	Color mixing system - White	0 - 100%	0..255
21 Set 7&8 Red	Color mixing system - Red	0 - 100%	0..255
22 Set 7&8 Green	Color mixing system - Green	0 - 100%	0..255
23 Set 7&8 Blue	Color mixing system - Blue	0 - 100%	0..255
24 Set 7&8 White	Color mixing system - White	0 - 100%	0..255
25 Set 9&10 Red	Color mixing system - Red	0 - 100%	0..255
26 Set 9&10 Green	Color mixing system - Green	0 - 100%	0..255
27 Set 9&10 Blue	Color mixing system - Blue	0 - 100%	0..255
28 Set 9&10 White	Color mixing system - White	0 - 100%	0..255

5.5 Dual Pixel High Resolution Mode (DPiH) 29 DMX Channels:

Channel	Function	Time and Value	DMX
1 Tilt - High	Tilt coarse	0° - 210°	0..255
2 Tilt - Low	Tilt fine		0..255
3 Shutter	Shutter closed		0..15
	Shutter pulse random	slow – fast	16..47
	Fade on, snap off (random patterns)	slow – fast	48..79
	Snap on, fade off (random patterns)	slow – fast	80..111
	Fade on, fade off (random patterns)	slow – fast	112..143
	Strobe random	5s - 0.1s	144..199
	Strobe effect slow - fast	1 Hz - 10 Hz	200..239
	Shutter open		240..255
4 Intensity - High	Intensity - coarse	0 - 100%	0..255
5 Intensity - Low	Intensity - fine	-	0..255
6 CTO	No CTO	Applicable	0..7
	Continuous color temperature correction	for ALL colors	8..255
7 Special ⁵⁾	See special features below ⁵⁾	-	-
8 Crossfade	0..2 seconds transition time		0..255
9 Zoom	Wide (flood) - narrow (spot)	50° - 7°	0..255
10 Set 1&2 Red	Color mixing system - Red	0 - 100%	0..255
11 Set 1&2 Green	Color mixing system - Green	0 - 100%	0..255
12 Set 1&2 Blue	Color mixing system - Blue	0 - 100%	0..255
13 Set 1&2 White	Color mixing system - White	0 - 100%	0..255
14 Set 3&4 Red	Color mixing system - Red	0 - 100%	0..255
15 Set 3&4 Green	Color mixing system - Green	0 - 100%	0..255
16 Set 3&4 Blue	Color mixing system - Blue	0 - 100%	0..255
17 Set 3&4 White	Color mixing system - White	0 - 100%	0..255
18 Set 5&6 Red	Color mixing system - Red	0 - 100%	0..255
19 Set 5&6 Green	Color mixing system - Green	0 - 100%	0..255
20 Set 5&6 Blue	Color mixing system - Blue	0 - 100%	0..255
21 Set 5&6 White	Color mixing system - White	0 - 100%	0..255
22 Set 7&8 Red	Color mixing system - Red	0 - 100%	0..255
23 Set 7&8 Green	Color mixing system - Green	0 - 100%	0..255
24 Set 7&8 Blue	Color mixing system - Blue	0 - 100%	0..255
25 Set 7&8 White	Color mixing system - White	0 - 100%	0..255
26 Set 9&10 Red	Color mixing system - Red	0 - 100%	0..255
27 Set 9&10 Green	Color mixing system - Green	0 - 100%	0..255
28 Set 9&10 Blue	Color mixing system - Blue	0 - 100%	0..255
29 Set 9&10 White	Color mixing system - White	0 - 100%	0..255

5.6 Single Pixel Mode (spix) 48 DMX Channels:

Channel	Function	Time and Value	DMX
1 Tilt - High	Tilt coarse	0° - 210°	0..255
2 Tilt - Low	Tilt fine		0..255
3 Shutter	Shutter closed		0..15
	Shutter pulse random	slow – fast	16..47
	Fade on, snap off (random patterns)	slow – fast	48..79
	Snap on, fade off (random patterns)	slow – fast	80..111
	Fade on, fade off (random patterns)	slow – fast	112..143
	Strobe random	5s - 0.1s	144..199
	Strobe effect slow - fast	1 Hz - 10 Hz	200..239
	Shutter open		240..255
4 Intensity	Intensity	0 - 100%	0..255
5 CTO	No CTO		0..7
	Continuous color temperature correction	Applicable for ALL colors	8..255
6 Special ⁵⁾	See special features below ⁵⁾	-	-
7 Crossfade	0..2 seconds transition time		0..255
8 Zoom	Wide (flood) - narrow (spot)	50° - 7°	0..255
9 Set 1 Red	Color mixing system - Red	0 - 100%	0..255
10 Set 1 Green	Color mixing system - Green	0 - 100%	0..255
11 Set 1 Blue	Color mixing system - Blue	0 - 100%	0..255
12 Set 1 White	Color mixing system - White	0 - 100%	0..255
13 Set 2 Red	Color mixing system - Red	0 - 100%	0..255
14 Set 2 Green	Color mixing system - Green	0 - 100%	0..255
15 Set 2 Blue	Color mixing system - Blue	0 - 100%	0..255
16 Set 2 White	Color mixing system - White	0 - 100%	0..255
17 Set 3 Red	Color mixing system - Red	0 - 100%	0..255
18 Set 3 Green	Color mixing system - Green	0 - 100%	0..255
19 Set 3 Blue	Color mixing system - Blue	0 - 100%	0..255
20 Set 3 White	Color mixing system - White	0 - 100%	0..255
21 Set 4 Red	Color mixing system - Red	0 - 100%	0..255
22 Set 4 Green	Color mixing system - Green	0 - 100%	0..255
23 Set 4 Blue	Color mixing system - Blue	0 - 100%	0..255
24 Set 4 White	Color mixing system - White	0 - 100%	0..255
25 Set 5 Red	Color mixing system - Red	0 - 100%	0..255
26 Set 5 Green	Color mixing system - Green	0 - 100%	0..255
27 Set 5 Blue	Color mixing system - Blue	0 - 100%	0..255

28 Set 5 White	Color mixing system - White	0 - 100%	0..255
29 Set 6 Red	Color mixing system - Red	0 - 100%	0..255
30 Set 6 Green	Color mixing system - Green	0 - 100%	0..255
31 Set 6 Blue	Color mixing system - Blue	0 - 100%	0..255
32 Set 6 White	Color mixing system - White	0 - 100%	0..255
33 Set 7 Red	Color mixing system - Red	0 - 100%	0..255
34 Set 7 Green	Color mixing system - Green	0 - 100%	0..255
35 Set 7 Blue	Color mixing system - Blue	0 - 100%	0..255
36 Set 7 White	Color mixing system - White	0 - 100%	0..255
37 Set 8 Red	Color mixing system - Red	0 - 100%	0..255
38 Set 8 Green	Color mixing system - Green	0 - 100%	0..255
39 Set 8 Blue	Color mixing system - Blue	0 - 100%	0..255
40 Set 8 White	Color mixing system - White	0 - 100%	0..255
41 Set 9 Red	Color mixing system - Red	0 - 100%	0..255
42 Set 9 Green	Color mixing system - Green	0 - 100%	0..255
43 Set 9 Blue	Color mixing system - Blue	0 - 100%	0..255
44 Set 9 White	Color mixing system - White	0 - 100%	0..255
45 Set 10 Red	Color mixing system - Red	0 - 100%	0..255
46 Set 10 Green	Color mixing system - Green	0 - 100%	0..255
47 Set 10 Blue	Color mixing system - Blue	0 - 100%	0..255
48 Set 10 White	Color mixing system - White	0 - 100%	0..255

5.7 Single Pixel High Resolution (SPixH) Mode 49 DMX Channels:

Channel	Function	Time and Value	DMX
1 Tilt - High	Tilt coarse	0° - 210°	0..255
2 Tilt - Low	Tilt fine		0..255
3 Shutter	Shutter closed		0..15
	Shutter pulse random	slow – fast	16..47
	Fade on, snap off (random patterns)	slow – fast	48..79
	Snap on, fade off (random patterns)	slow – fast	80..111
	Fade on, fade off (random patterns)	slow – fast	112..143
	Strobe random	5s - 0.1s	144..199
	Strobe effect slow - fast	1 Hz - 10 Hz	200..239
	Shutter open		240..255
4 Intensity - High	Intensity - coarse	0 - 100%	0..255
5 Intensity - Low	Intensity - fine	-	0..255
6 CTO	No CTO		0..7
	Continuous color temperature correction	Applicable for ALL colors	8..255
7 Special ⁵⁾	See special features below ⁵⁾	-	-
8 Crossfade	0..2 seconds transition time		0..255
9 Zoom	Wide (flood) - narrow (spot)	50° - 7°	0..255
10 Set 1 Red	Color mixing system - Red	0 - 100%	0..255
11 Set 1 Green	Color mixing system - Green	0 - 100%	0..255
12 Set 1 Blue	Color mixing system - Blue	0 - 100%	0..255
13 Set 1 White	Color mixing system - White	0 - 100%	0..255
14 Set 2 Red	Color mixing system - Red	0 - 100%	0..255
15 Set 2 Green	Color mixing system - Green	0 - 100%	0..255
16 Set 2 Blue	Color mixing system - Blue	0 - 100%	0..255
17 Set 2 White	Color mixing system - White	0 - 100%	0..255
18 Set 3 Red	Color mixing system - Red	0 - 100%	0..255
19 Set 3 Green	Color mixing system - Green	0 - 100%	0..255
20 Set 3 Blue	Color mixing system - Blue	0 - 100%	0..255
21 Set 3 White	Color mixing system - White	0 - 100%	0..255
22 Set 4 Red	Color mixing system - Red	0 - 100%	0..255
23 Set 4 Green	Color mixing system - Green	0 - 100%	0..255
24 Set 4 Blue	Color mixing system - Blue	0 - 100%	0..255
25 Set 4 White	Color mixing system - White	0 - 100%	0..255
26 Set 5 Red	Color mixing system - Red	0 - 100%	0..255
27 Set 5 Green	Color mixing system - Green	0 - 100%	0..255

28	Set 5 Blue	Color mixing system - Blue	0 - 100%	0..255
29	Set 5 White	Color mixing system - White	0 - 100%	0..255
30	Set 6 Red	Color mixing system - Red	0 - 100%	0..255
31	Set 6 Green	Color mixing system - Green	0 - 100%	0..255
32	Set 6 Blue	Color mixing system - Blue	0 - 100%	0..255
33	Set 6 White	Color mixing system - White	0 - 100%	0..255
34	Set 7 Red	Color mixing system - Red	0 - 100%	0..255
35	Set 7 Green	Color mixing system - Green	0 - 100%	0..255
36	Set 7 Blue	Color mixing system - Blue	0 - 100%	0..255
37	Set 7 White	Color mixing system - White	0 - 100%	0..255
38	Set 8 Red	Color mixing system - Red	0 - 100%	0..255
39	Set 8 Green	Color mixing system - Green	0 - 100%	0..255
40	Set 8 Blue	Color mixing system - Blue	0 - 100%	0..255
41	Set 8 White	Color mixing system - White	0 - 100%	0..255
42	Set 9 Red	Color mixing system - Red	0 - 100%	0..255
43	Set 9 Green	Color mixing system - Green	0 - 100%	0..255
44	Set 9 Blue	Color mixing system - Blue	0 - 100%	0..255
45	Set 9 White	Color mixing system - White	0 - 100%	0..255
46	Set 10 Red	Color mixing system - Red	0 - 100%	0..255
47	Set 10 Green	Color mixing system - Green	0 - 100%	0..255
48	Set 10 Blue	Color mixing system - Blue	0 - 100%	0..255
49	Set 10 White	Color mixing system - White	0 - 100%	0..255

The Pixel are numbered left to right 1 – 10 as shown below.

Tilt DMX Value = 0 / “Display” to the front / “Power & DMX In” to the left.

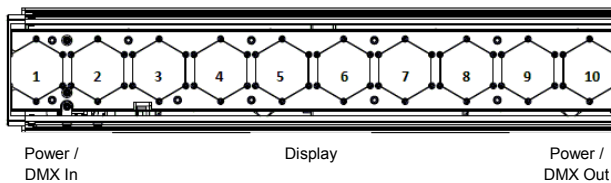

¹⁾ The predefined colors can be used as start-colors for the Rainbow effect. Please select first a desired start-color before you activate the rainbow effect. All **IMPRESSION X4 Bar 10** will then start from that color and will execute the rainbow effect synchronously. Different **IMPRESSION X4 Bar 10** can have different start-colors but will still execute the rainbow effect synchronously. If you choose a color different from the ones marked with ¹⁾ in the tables above the rainbow start-color will be red.

²⁾ Rainbow-effect Stop will pause this function. After resuming the rainbow-effect will be continued from the current color.

3) The Rainbow-effect will run synchronously only if started from one of the predefined colors (see also 1) before).

4) Set 1 is the main layer while Set 2 and Set 3 are background layers.

Thus Set 2 is only visible on the unlit pixel of layer 1 if a pattern is applied and Set 3 is only visible on the unlit pixel of layer 1 and 2 if there are patterns applied.

5) Special Channel Function Overview:

DMX value		Active	Function	Save to eeprom	Remarks
from	to				
0	3	not in	no mirror	no	
4	7	SPix/DPix/SPixH/DPixH	mirror color priority	no	
8	11	mode	mirror color mixing	no	
The following switch boxes only work if special channel has been enabled with DMX value zero (0) before:					
120	123	3 seconds	Tilt slow mode off	yes	
124	127	3 seconds	Tilt slow mode on	yes	Only if shutter=48..49 and intensity=50..59 (12800..15104 at high resolution).
128	131	3 seconds	Tilt current off	yes	
132	135	3 seconds	Tilt current on	yes	Requires Tilt Firmware V.20 or later. ⁶⁾
136	139	3 seconds	Tilt reset off	yes	
140	143	3 seconds	Tilt reset on	yes	
144	147	3 seconds	Display Flip off	yes	
148	151	3 seconds	Display Flip on	yes	
152	155	3 seconds	DMX Mode DPixH (HiRes)	yes	Only if shutter=48..49 and intensity=50..59 (12800..15104 at high resolution)
156	159	3 seconds	DMX Mode SPixH (HiRes)	yes	
160	163	3 seconds	DMX Mode High Resolution	yes	
164	167	3 seconds	DMX Mode Normal	yes	
168	171	3 seconds	DMX Mode Compressed	yes	
172	175	3 seconds	DMX Mode DPix	yes	
176	179	3 seconds	DMX Mode SPix	yes	
180	183	3 seconds	Dimmer Curve ESoft	yes	
184	187	3 seconds	Dimmer Curve Soft	yes	
188	191	3 seconds	Dimmer Curve Lin	yes	
192	195	3 seconds	X4 Compatibility off	yes	
196	199	3 seconds	X4 Compatibility on	yes	
200	203	3 seconds	Silent-Mode off	yes	
204	207	3 seconds	Silent-Mode on	yes	
208	211	3 seconds	Position Feedback off	yes	
212	215	3 seconds	Position Feedback on	yes	
216	219	3 seconds	DMX hold off	yes	
220	223	3 seconds	DMX hold on	yes	
224	227	3 seconds	Tilt inverse off	yes	
228	231	3 seconds	Tilt inverse on	yes	
232	235	3 seconds	Pixel inverse off	yes	
236	239	3 seconds	Pixel inverse on	yes	
240	243	3 seconds	Zoom inverse off	yes	
244	247	3 seconds	Zoom inverse on	yes	
248	251	3 seconds	Fixture default	yes	Only if shutter=48..49 and intensity=50..59 (12800..15104 at high resolution)
252	255	3 seconds	Fixture reset	no	

⁶⁾ For further information please contact your local GLP dealer or GLP support center.

6 Accessories

6.1 Optional diffuser filter:

The clear acrylic front cover is exchangeable with different diffusion or frost filters. A diffusion filter with 3° vertical & 30° horizontal spread is already included with your **impression X4 Bar 10**.

For other filter options please contact your local GLP dealer.

To remove the installed cover pull down the latch shown below and pull the filter out.

To insert the new filter pull the latch down again and slide in the new filter until fully inserted, then release the latch to secure the new filter.

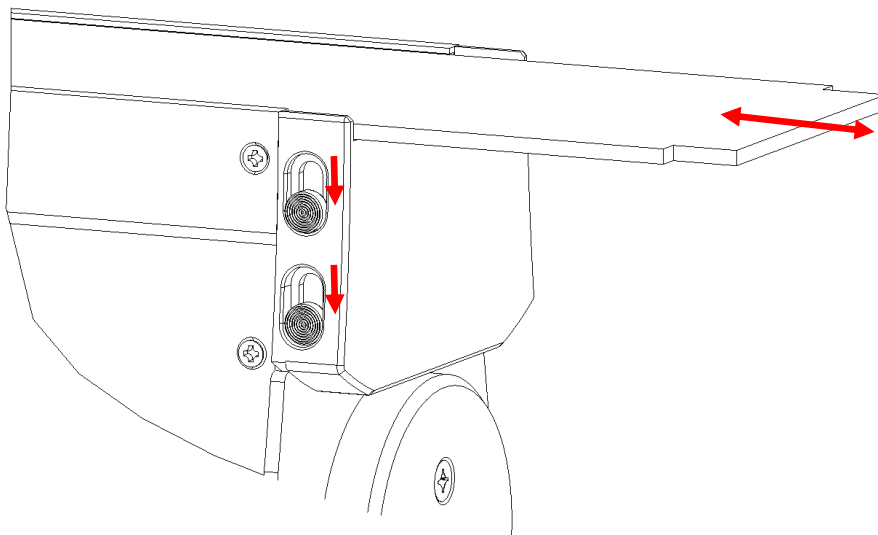

7 Maintaining and Cleaning

The **IMPRESSION X4 Bar 10** is a fixture of very low maintenance. It is only necessary to clean the air inlets and outlets as well as the optical LED lenses from time to time. For safe operation it is absolutely essential that the fixture is kept clean and that dust, dirt and smoke-fluid residues must not build up on, or within the fixture. Otherwise the fixture's light-output will be significantly reduced or damages can occur. Regular cleaning will not only ensure the maximum light-output, but will also allow the fixture to operate reliably throughout its life.

A soft lint-free cloth moistened with any good glass cleaning fluid is recommended to clean the lenses.



Attention:

Under no circumstances should alcohol or solvents be used to clean the lenses!

7.1 Safety regulations

- **Pull out the mains power plug!**
- Wait min. 15 minutes after disconnecting power to allow the fixture to cool down.

7.2 Maintenance and Interval (rule-of-thumb)

The contamination of the fixture depends on the environment details. Hence no general guidelines can be given. The intervals given below are only suggestions from our experience.

Position	Interval	In this way
LED reflector and optical system	weekly	soft brush /lint-free cloth
Fan and air channel	monthly	vacuum cleaner, airbrush, etc.

Attention:

- **Never let optical parts come into contact with oil, grease, alcohol or similar solvents.**
- **Before running the fixture wait until all parts are dry.**
- **Never touch lenses with bare fingers.**

8 Technical Specifications:

Power supply	
Power consumption	200 VA (Watt)
Power Input	Auto sensing 100-240 V AC, 50-60 Hz
Fuse protection	Micro-fuse 5x20 mm, T5A
Operational Parameters	
Max. Ambient Temperature	5° - 45°C (integrated overheating switch) 40°-113°F
Mounting Position	Any (see relevant chapter in the manual)
Lighting System - Additive Color mixing	
LED Type	10 x Osram Ostar RGBW multi-chip
Lifetime	50,000 h
Wavelength optimized for maximum presentable color space	
Optical System	
Full RGBW / High efficient Collimator cluster Exchangeable diffuser filters available (optional).	
Shutter / Dimmer (8/16 Bit)	
Strobe- Effect with variable speed between 1-10 flashes per second, Random- & Pulse-Effects Continuous Dimmer 0 - 100%	
Zoom	
7 to 50 degree continuous high speed zoom	
Optical Patterns	
Several pre-defined beam patterns with direct access and manipulation. Free control of every pixel, color and intensity	
DMX Control	
Standard USITT DMX-512, 5 pin XLR: [+]=Pin 3 / [-]=Pin 2 / [Ground]=Pin 1 / Pin 4&5 N.C. The DMX- Addressing starts at the DMX channel [001].	
Tilt (8/16 Bit)	
Tilt- movement	210° in min. 1.5 seconds (Position Feedback)
Weights and Measures	
Length	500 mm / 19.7''
Width	100 mm / 3.9''
Height	240 mm / 9.4''
Weight (net)	8.0 kg / 17.6 lbs
Weight with bracket	9.8 kg / 21.6 lbs

9 Dimensions

